

# ***MagVibe*** ***Pro***

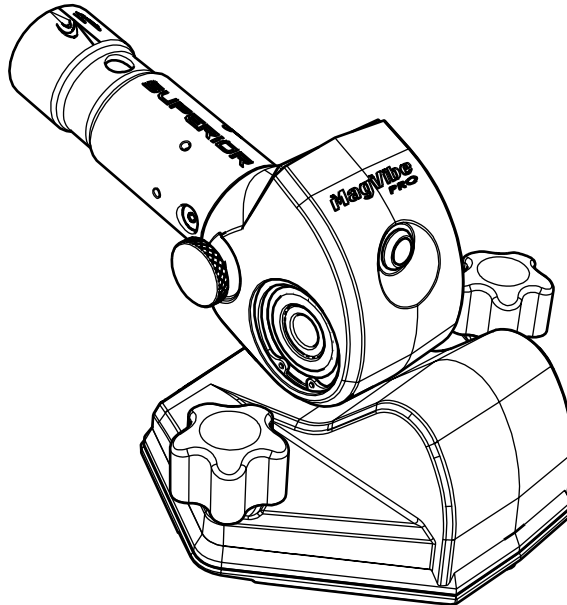

## **User Manual and Parts List**

P/n: 017821



## General

### Safety symbols:



WARNING! If used incorrectly the machine can cause injury.



Please read the Operator's Manual thoroughly making sure you understand how to use the machine before use.



Always wear personal protective equipment such as gloves, eye protection, hearing protection, and a hard hat. Jobsites might require certain protective equipment be used due to national and local regulations and insurance policies. Make sure you check with the jobsite foreman for requirements before work begins.

### Dear Customer,

Thank you for choosing a Superior Innovation product. It is our intent to deliver the best products possible. Delivering innovative, well-built, ergonomic, efficient products is our goal to help you do the best job possible. Safety, and innovation are our cornerstone of design.

This Operator's Manual is a valuable document. Make sure it is always accessible when using the machine. If you lend or sell this machine, make sure that this document is also transferred, so the new user will know how to properly use and maintain it.

## **User Responsibility**

It is the owner's / employer's responsibility to ensure that the operator is properly trained and has sufficient knowledge about how to use this machine safely. Supervisors and operators must read and understand the Operators Manual. They must be aware of the safety instructions, limitations, proper use and maintenance. Local and national legislation may regulate the use of this machine. Find out what legislations are applicable in your location before use.

## **Superior Innovations Reservation**

All of the information and data in this Operator's Manual was up to date at the time the Operator's Manual was sent to print. Superior Innovations research and development is continually working on product development and improvements. Therefore, we reserve the right to modify the design, appearance and features of the product without prior notice.

## Vibration Warning



WARNING! Overexposure to vibration can lead to circulatory damage and or nerve damage, especially in people who have impaired circulation. Contact your doctor if you experience symptoms of overexposure to vibration. Symptoms include: numbness, loss of feeling, tingling, pricking, pain, loss of strength, and changes in skin color and condition. These conditions normally occur in the fingers, hands or wrists and can be further increased in cold temperatures.

## Transportation and Storage

After work is completed, remove the MagVibe™ Pro or ProTilt® from the float and thoroughly wipe down before the concrete has time to setup. **DO NOT USE A PRESSURE WASHER OR SUBMERGE IN WATER!** There are sensitive electronics and not all areas can be water tight.

Secure the equipment during transportation to avoid transport damage and accidents.

Store in a lockable area so that it is not able to be accessed by children or unauthorized persons.

## Personal Protective Equipment

You must use approved personal protective equipment whenever you use the machine. Personal protective equipment cannot eliminate injury, but it will reduce the degree of injury if an accident does happen. Ask your dealer for help in choosing the right protective equipment.

## **Common Sense**

It is not possible to cover every conceivable situation. Exercise care and use common sense if you get into a situation where you feel unsafe. Stop and seek expert advice by contacting Superior Innovations, Inc., a service dealer or an experienced user. Do not attempt any task that you are unsure of.

## **Work Area Safety**

Observe your surroundings to ensure nothing can affect your control of the machine.

Observe your surroundings to ensure there is no risk of people or animals that can come into contact with the machine while in operation.

Do not use machine in bad weather, such as heavy rain, strong winds, intense cold, or heavy fog. Working in such weather is trying and can lead to difficult situations.

Ensure that the work area is sufficiently illuminated to create a safe working environment.

Make sure that there are no electrical cables routed in the working area.

Make sure that the work area is clear, clean and free of obstacles that can cause trips or spills.

## Before Starting

Inspect equipment to ensure that there are no loose fasteners, cracks, leaks, or other obvious damage. If there are do not use until the problems are corrected.

Make sure that daily maintenance has been completed.

Make sure that the MagVibe™ Pro battery is fully charged.

## In the Box

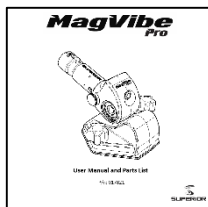
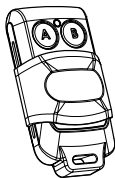
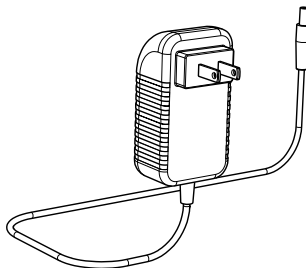
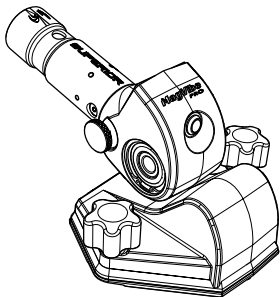

## Warranty

New equipment sold by Superior Innovations is warranted to be free from manufacturing defects under normal service for a period of one (1) year from date of purchase by the original consumer. Component manufacturers offer separate warranties and are covered separately. These components are the lithium polymer battery, the electric motor, RF remote control batteries (27A) and the battery indicator. These components carry a 180-day warranty from the original date of purchase. For complete information or to request a return goods authorization number (RGA#) call technical service at (844) 624-8423.

Superior Innovation's obligation under this warranty is expressly limited to the replacement or repair at our service facility or one that has been pre-authorized by Superior Innovations.

This warranty does not apply to defects caused by damage, unreasonable use, faulty repairs made by others or defects caused by failure to provide reasonable maintenance, while in the possession of the consumer. Further, the warranty is void if the product, or any of its components, is altered or modified by the consumer or if the product is used in an inappropriate manner not recommended by the manufacturer.

## Description / Features / Controls

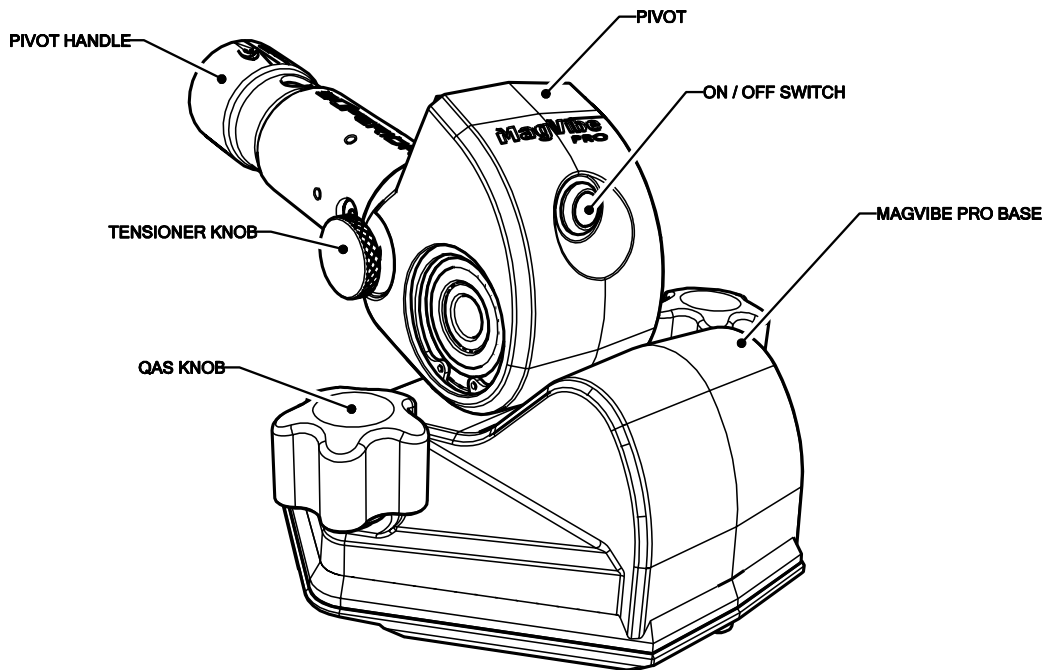



## Description / Features / Controls

Rotating the pivot handle will pivot the MagVibe Pro base.  
From stop to stop is 50°.

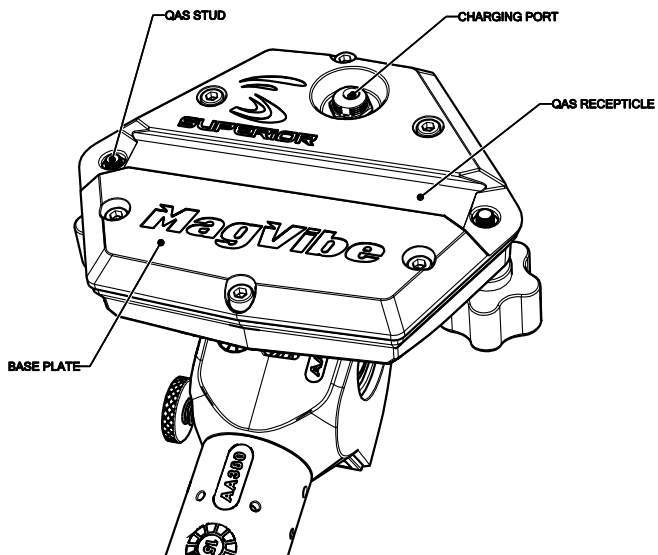
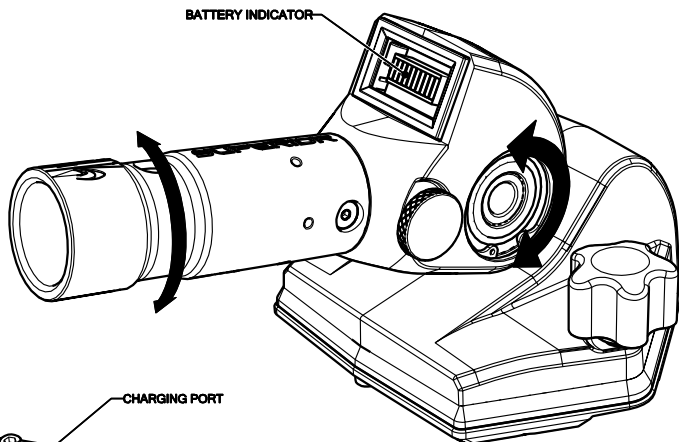

# QAS

## QUICK ATTACH SYSTEM

QAS™ is a quick attach system designed to make it quick and easy to attach a Magvibe™ Pro, ProTilt®, or accessories to a ProFloat® or other manufacturers floats. The ability to quickly Remove the pivot allows for stacking of floats for transportation, easier cleanup and the ability to switch floats very fast. The Magvibe™ Pro, ProTilt® and ProFloat® have a built-in QAS™ mounts. For other types of floats there are a variety of QAS™ adapters: The QAS™-M is a four bolt adapter, the QAS™-W is a t-washer adapter for channel mount floats. There is also a QAS™-F adapter that converts a standard pivot to have a quick attach system so you can attach to a ProFloat®.

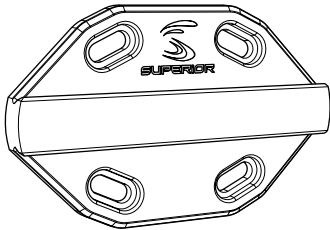

QAS™-M Adapter

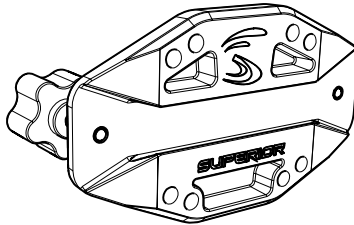

QAS™-F Adapter

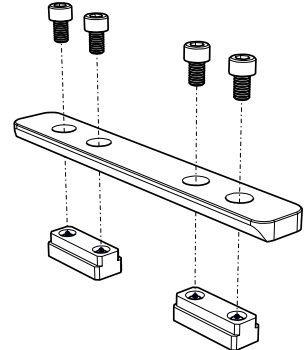

QAS™-W Adapter

## ProFloat© Attachment

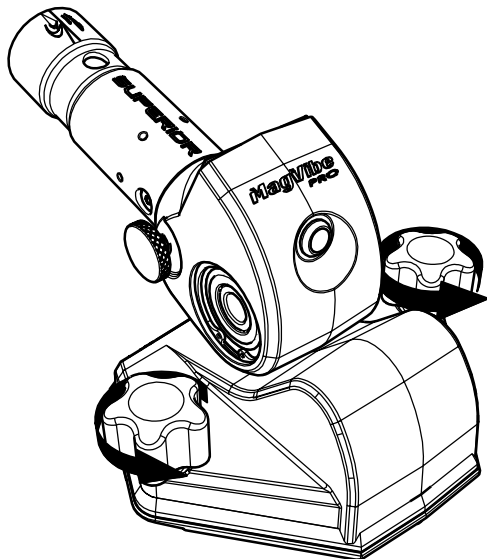

Loosen both QAS™ knobs by turning them counter-clockwise.

Make sure that the threaded studs are retracted enough to clear the QAS™ dovetail.

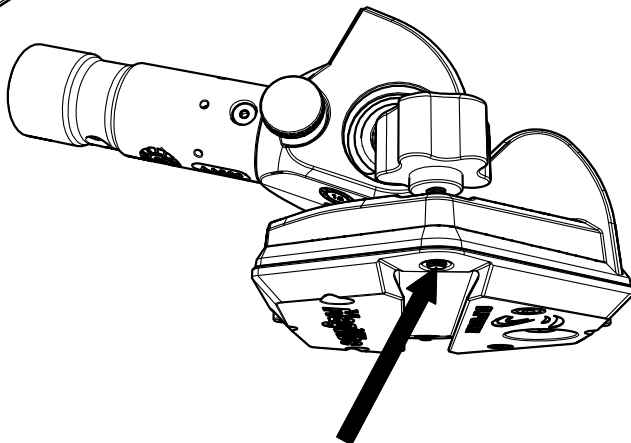

Align the QAS™  
receptacle with the  
QAS™ dovetail and  
slide over to engage.

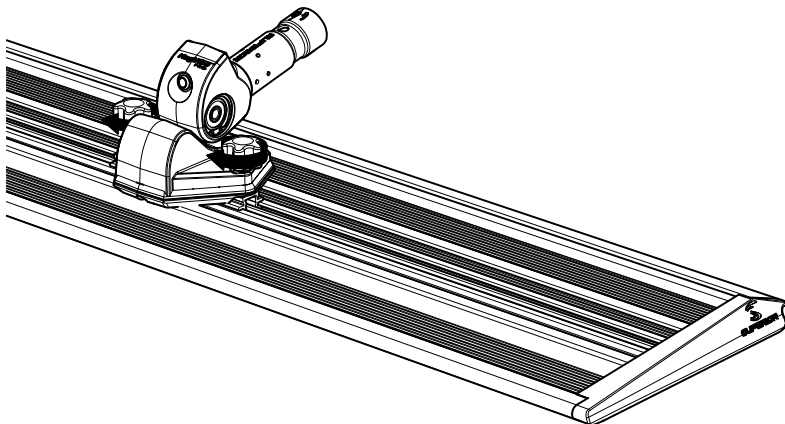
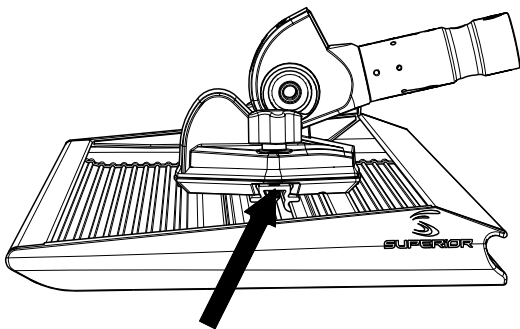
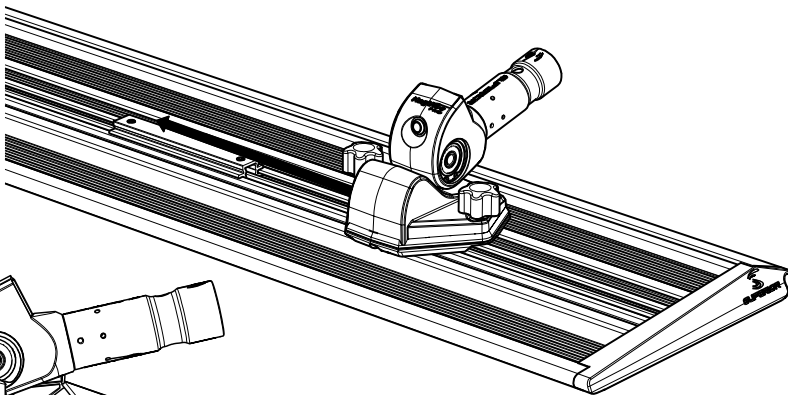

Center the  
MagVibe Pro™  
over the QAS™  
dovetail and  
tighten both QAS™  
knobs by turning  
them clockwise.

## Four Fastener Float Attachment (QAS™-M)

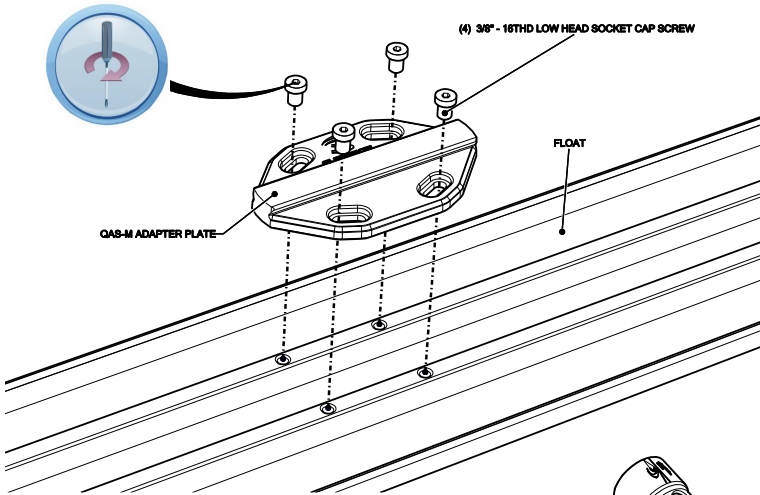

Place QAS™-M adapter onto four fastener float and tighten (4) 3/8"-16 x 1/2" Low head socket head cap screws (supplied with adapter). You will need a 3/16" Allen tool for this operation.

Loosen both QAS™ knobs by turning them counterclockwise. Make sure that the threaded studs are retracted enough to clear the dovetail.

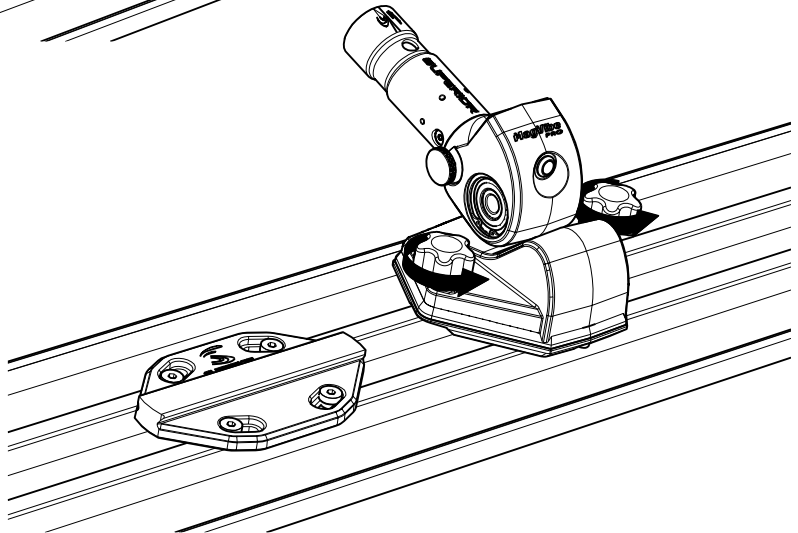

Align and slide the dovetail over the QAS™ receptacle located on the bottom of the Magvibe™, Protilt® or accessory.

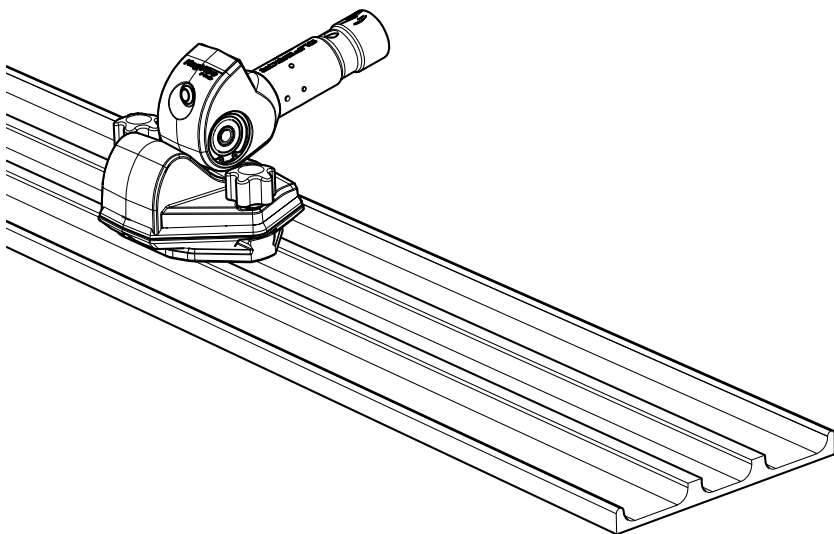
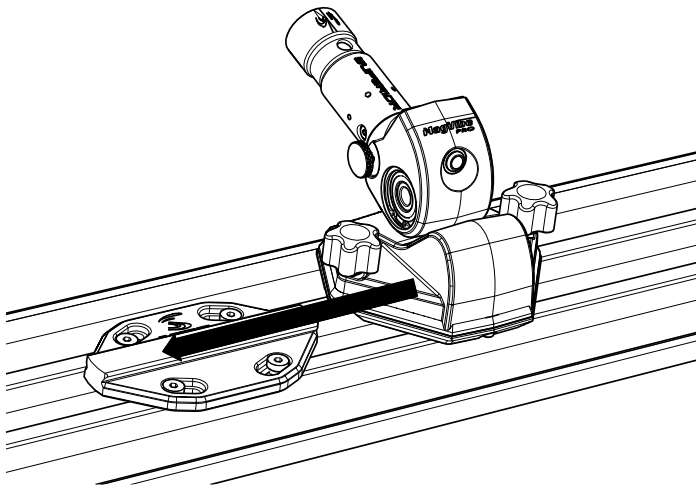

Tighten both QAS™ knobs by turning them clockwise.

## QAS™-W

Slide (2) QAS™-W T-washers into the channel of the float. Place the dovetail mount onto the float and tighten (4) M6 x 10mm socket head cap screws (supplied with adapter). You will need a 4mm Allen tool for this operation.

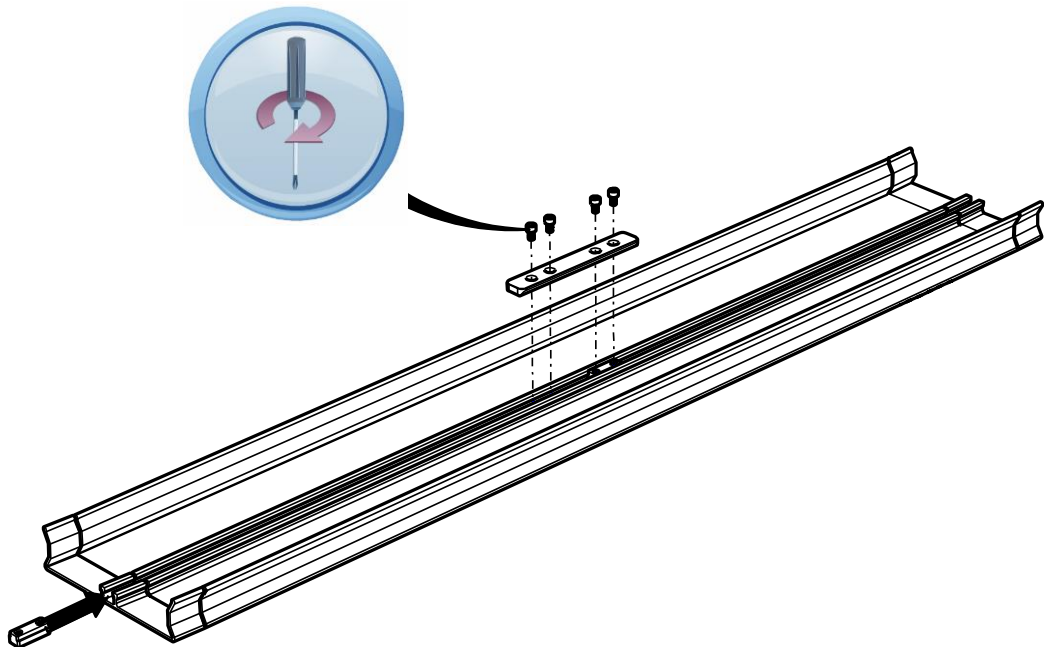

Loosen both QAS™ knobs by turning them counterclockwise. Make sure that the threaded studs are retracted enough to clear the dovetail.

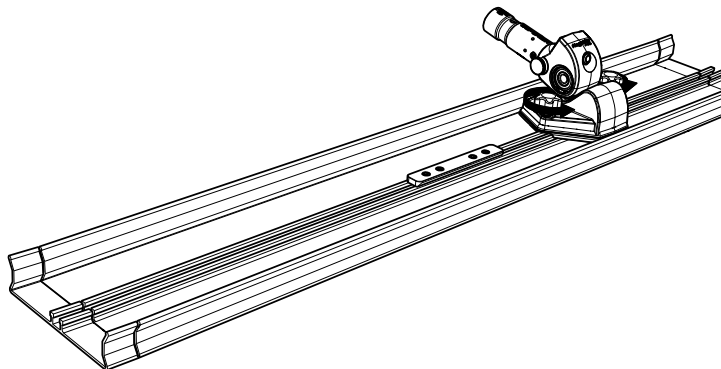

Align and slide the Magvibe™ Pro QAS™ receptacle over the dovetail on the QAS™-W adapter.

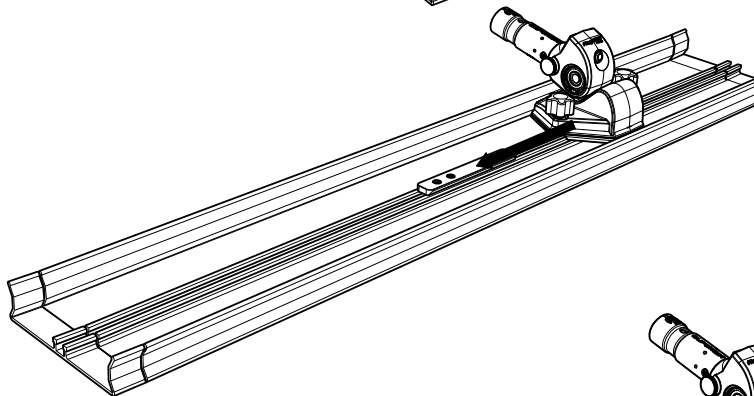

Tighten both QAS™ knobs by turning them clockwise.

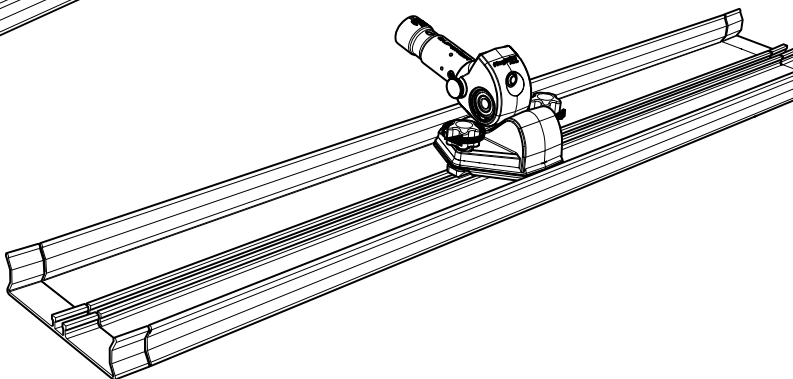



## Attaching the Pole Extension

Press and hold the pins in pole extension, then align and insert into Magvibe™ Pro pivot handle. Push into bore and make sure that the pins snap through the two holes in the pivot handle to engage.

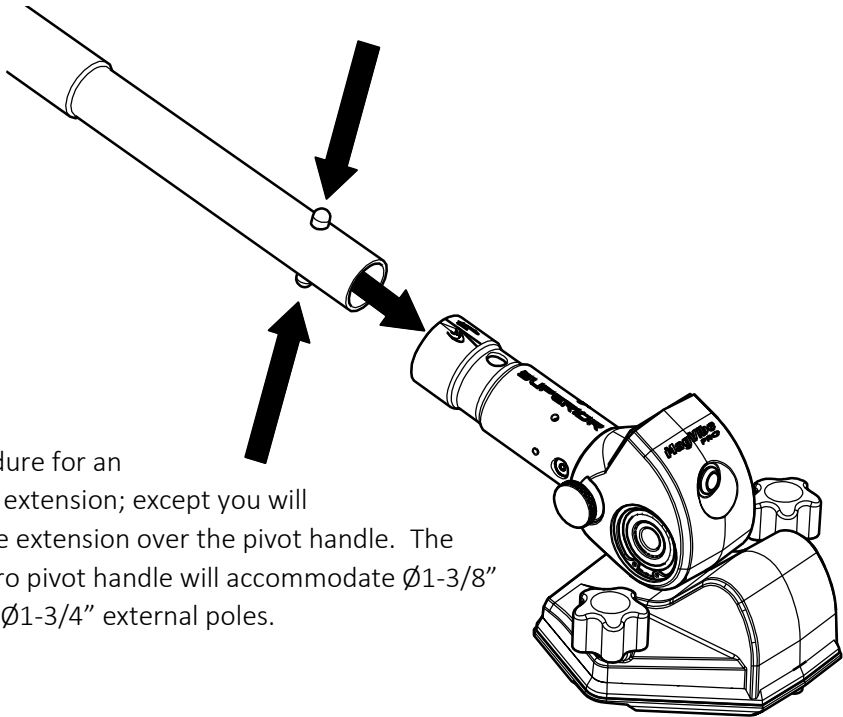

Same procedure for an outside pole extension; except you will slide the pole extension over the pivot handle. The Magvibe™ Pro pivot handle will accommodate  $\varnothing 1\text{-}3/8''$  internal and  $\varnothing 1\text{-}3/4''$  external poles.

## Turning Magvibe™ Pro On / Off

There are two ways to turn the Magvibe™ Pro on and off. The first method is to use the pre-programmed RF remote control (supplied) and the second is to depress the latching on / off switch.

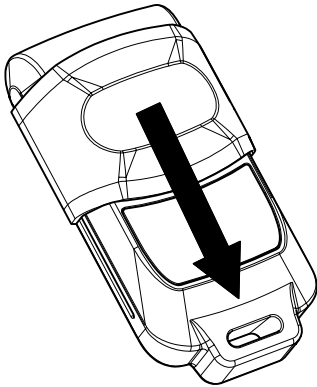

To use the RF remote control, slide the protective button cover downward to expose the buttons. There are two buttons: Button A turns the Magvibe™ Pro on and off, and Button B is an auxiliary RF control for powered accessories from Superior Innovations.

To turn the Magvibe™ Pro on, simply press button A and the vibration will start. When you want to turn it off, press button A again. The range will depend on surroundings, however, it should have a forty-foot line of sight range.



If you lose your RF remote control you can still turn the Magvibe™ Pro on and off by pressing the latching on / off switch.

**NOTE:** This switch is very compact and was designed to be used as a failsafe if the RF remote was lost.

### **Adjusting the Pivot Tensioner**

The pivot tension can be adjusted by the user to add pressure to the gear-set which creates friction to help hold the float at an angle. The end result is a fatigue reduction in the operator's wrist and hands.

To adjust; turn the tensioner knob clockwise. The more it is turned the more friction is applied to the gear-set. When you want less of an aid, turn the tensioner knob counterclockwise to reduce friction.

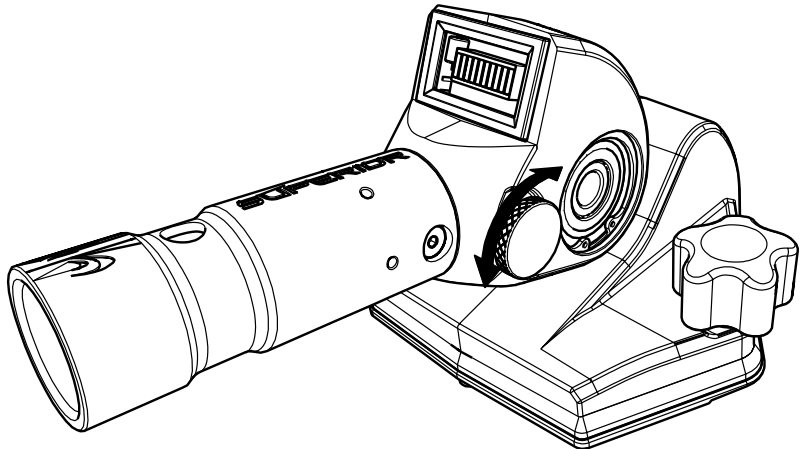
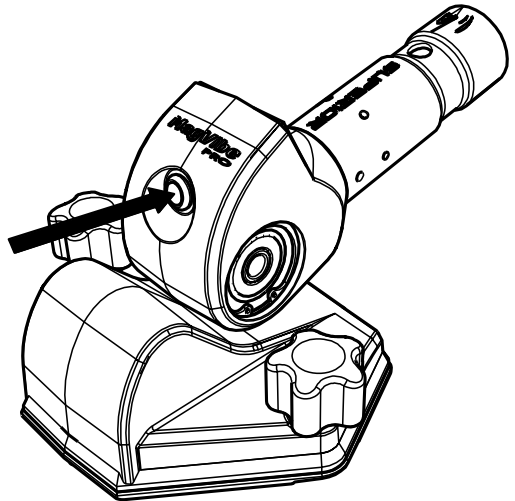

## Battery Indicator

The battery indicator is positioned so the operator can see the status of the battery when the Magvibe™ Pro is in operation. There are 10 LED's: 5 Green, 3 Amber and 2 Red. Every LED represents approximately 10% of battery life. For instance, if 6 LED'S are lit, you have approximately 60% of battery life remaining.

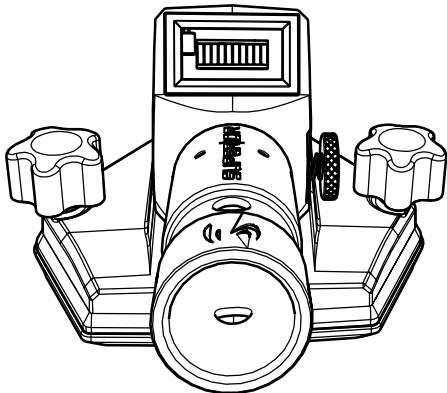

## Charging the Battery

The 18VDC Lithium Polymer battery is built in to the Magvibe™ Pro. It has 3000mAh capacity which should yield ~18hrs on a single charge. To charge it, plug the charger (supplied) into a 120 VAC wall outlet, and the 5mm charging plug into the charging port of the Magvibe™ Pro. The charging port is located underneath the QAS™ base plate and must be removed from the float to charge.

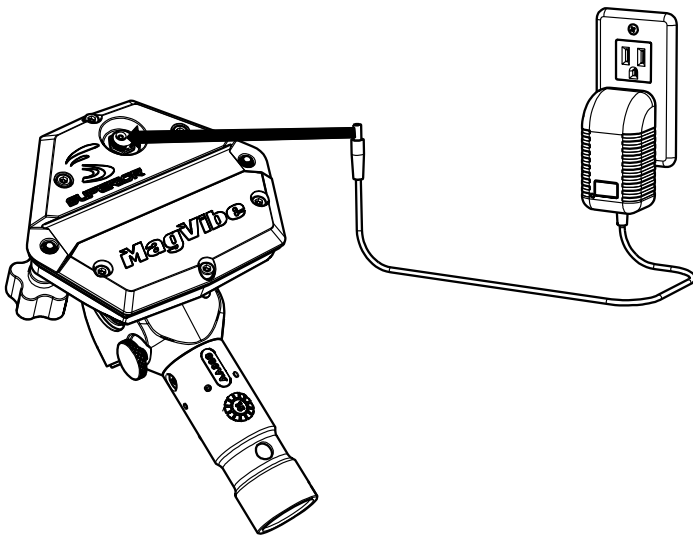

## Programming a Replacement Remote

If you lost your remote and need to program a replacement, you can do it yourself. You will need to order

part number D-13535. Once you receive your replacement remote, use a 4mm Allen key to remove (6) M5 socket head cap screws on the bottom plate as shown. Lift off the bottom plate to access the internal cavity of the Magvibe™ Pro. The plate may resist a bit due to the gasket sealer.

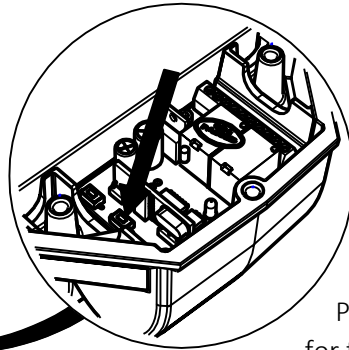
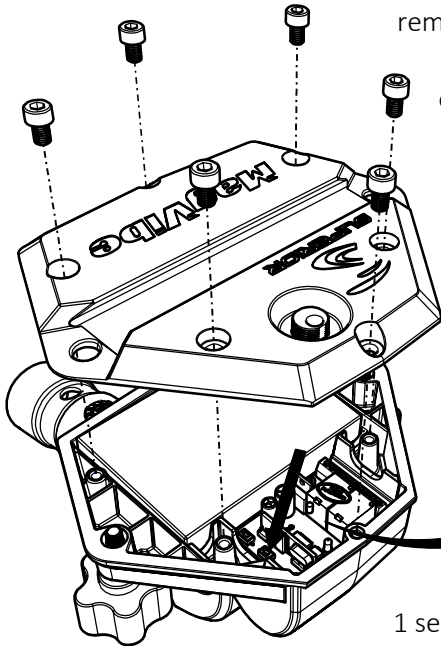

Once you are inside of the cavity, locate the RF / Motor controller board. The button indicated by the red arrow is P1 and it will be used for the programming of channel 1. Press and hold P1 for at least 1 second; the LED on the board will light for 1 second, go off for 1 second, and then light again.

Press and hold the A button on the remote control. If the code is successfully received; the LED will blink, and you can release the A button. If the code is unsuccessful; the LED will light for 10 seconds as it finishes the learning cycle.

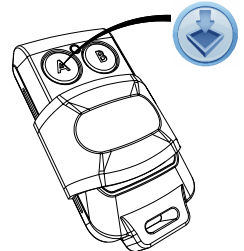

Once programming is successful, apply silicon sealer between the Magvibe™ Pro main body and baseplate. Then reassemble in reverse order.

### **Maintenance Statement**

The owner is responsible for the performance of all required maintenance, as described in the Operator's Manual.

### **Maintenance Schedule**

<b>Daily Maintenance</b>	<b>Weekly Maintenance</b>	<b>Monthly Maintenance</b>
Cleaning (external)	Cleaning (external)	Cleaning (external)
<b>Inspection</b>	<b>Inspection</b>	<b>Inspection</b>
loose fasteners, cracks, leaks, or other obvious damage	loose fasteners, cracks, leaks, or other obvious damage	loose fasteners, cracks, leaks, or other obvious damage
		<b>Grease gears</b> (see maintenance in Operator's Manual)

## Maintenance

Remove MagVibe™ Pro from the float and clean after every use. Make sure to pay special attention to the QAS™ receptacle. If concrete sets-up around the QAS™ it may become difficult to use. The MagVibe™ Pro has sensitive electronics located inside the pivot and the main body; **DO NOT USE A PRESSURE WASHER.**

*Tip:* Before use apply spray lubricant to the MagVibe™ Pro except to the battery indicator and the on/off switch. This will make it much easier to clean up after use.

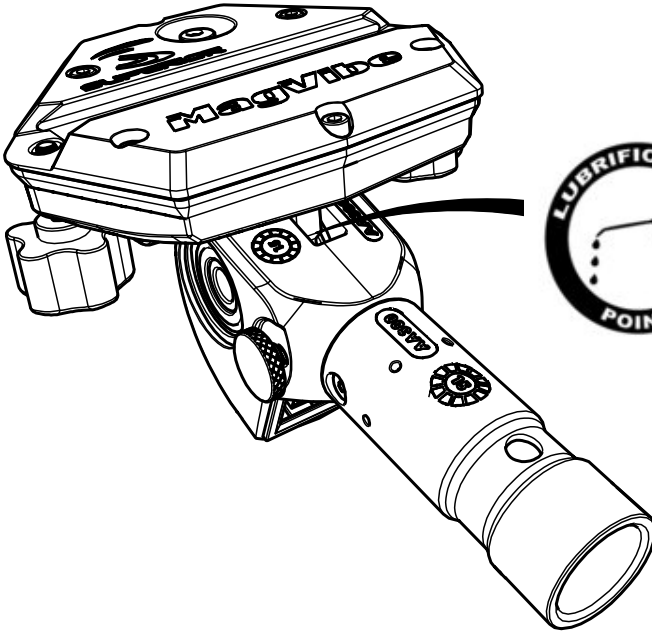

Once a month add grease to the gears by injecting it into the pivot joint as shown.

## RF Remote Battery Replacement

To replace the battery in the RF remote controller remove (4) screws on the back side of the RF remote control cover using a Philips screwdriver.

Remove the RF remote back cover plate.

Make note of the battery polarity.

Remove the RF controller board.

Remove the 27A battery. **MAKE SURE THAT THE POLARITY IS CORRECT.**

Install a new 27A battery.

Reinstall the RF controller board.

Place the RF remote back cover plate making sure to align the screw holes.

Reinstall the (4) screws and tighten using a Philips screwdriver. You may need to reprogram MagVibe Pro RF receiver if the code was lost during the battery reinstall process. See Programming a Lost Remote in this manual for instructions.

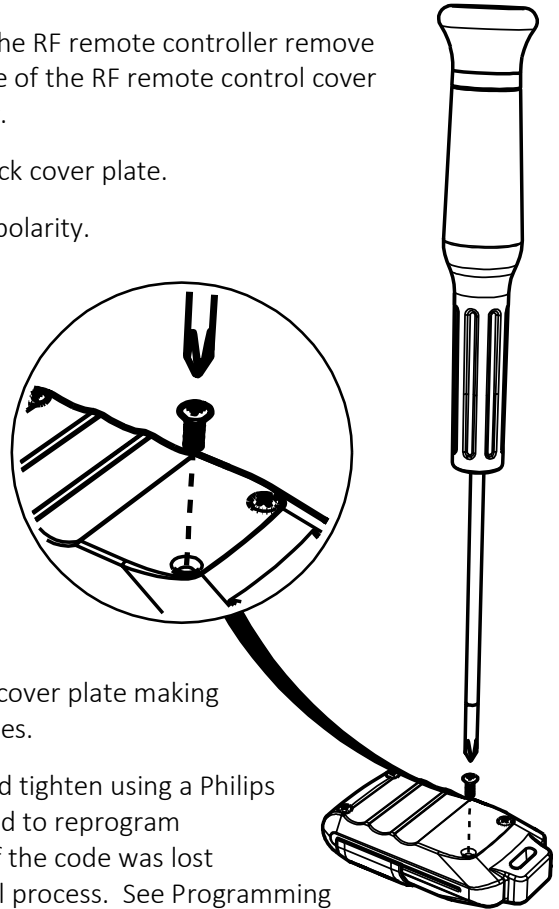



## Technical Data

Motor	24V DC, 0.6A
Battery	18V DC, 3000mAh Lithium Polymer
Weight	
Gears	Beveled, 3.17:1 ratio
Dimensional (L x W x H)	10.425" x 6.5" x 3.16" (264.8mm x 165.1mm x 80.3mm)

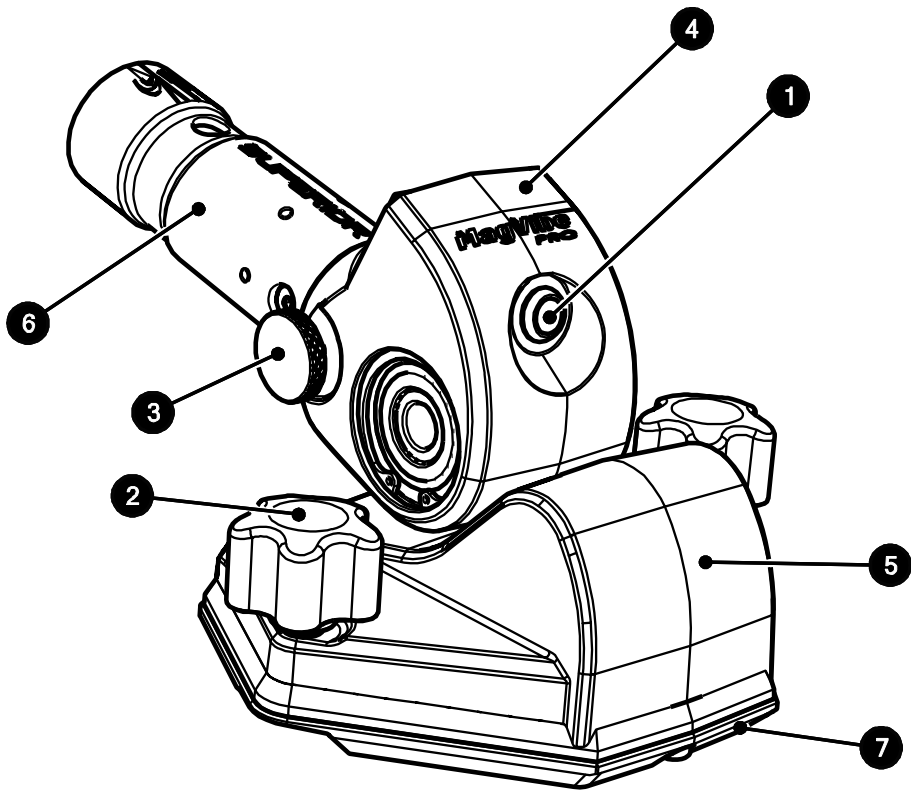

Part Number	BOM ID	Qty	Description
D-12725	1	1	ON / OFF SWITCH
D-12760	2	1	QAS KNOB
D-12761	3	1	TENSIONER KNOB
D-12409	4	1	D-12409
D-12431	5	1	MAGVIBE PRO CASTING MACHINED.SLDASM
D-12755	6	1	PIVOT HANDLE CASTING MACHINED
D-12344	7	1	QA MACHINED CASTING

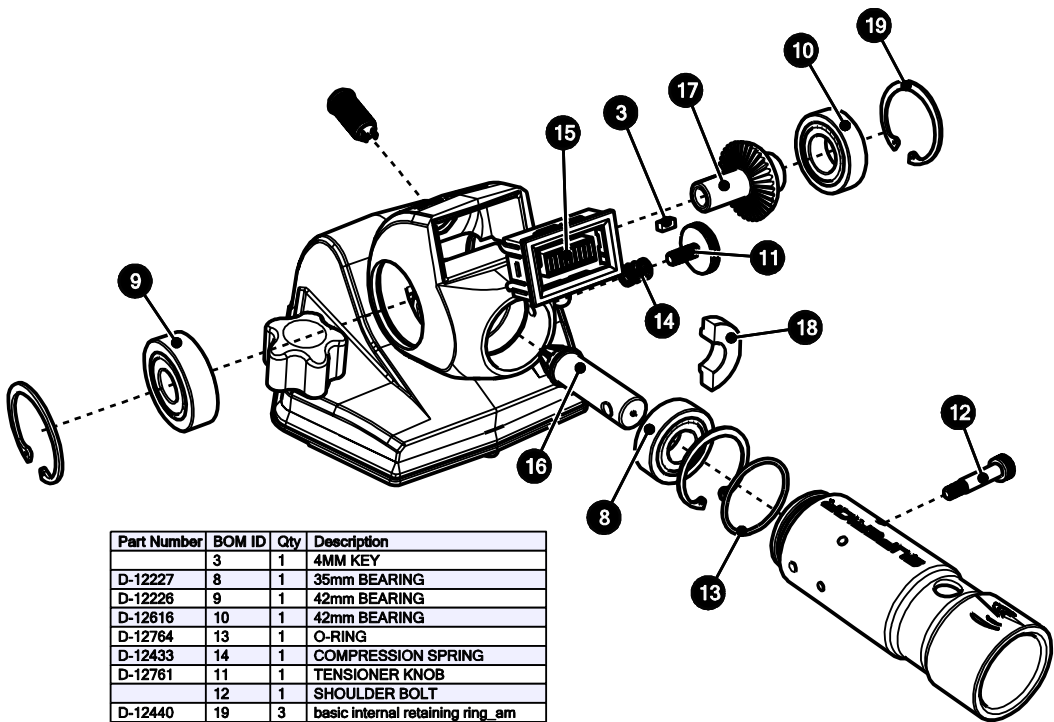

Part Number	BOM ID	Qty	Description
	3	1	4MM KEY
D-12227	8	1	35mm BEARING
D-12226	9	1	42mm BEARING
D-12616	10	1	42mm BEARING
D-12764	13	1	O-RING
D-12433	14	1	COMPRESSION SPRING
D-12761	11	1	TENSIONER KNOB
	12	1	SHOULDER BOLT
D-12440	19	3	basic internal retaining ring_am
D-12384	15	1	BATTERY INDICATOR ASSY
D-12380	16	1	DRIVE GEAR
D-12763	17	1	PIVOT GEAR
D-12762	18	1	TENSION ADJUSTMENT COLLAR

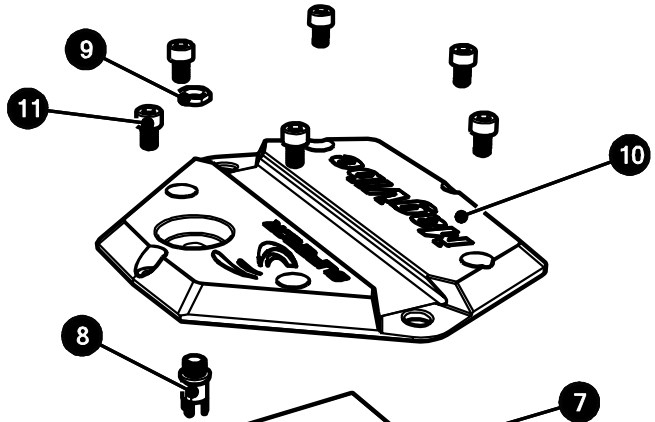

Part Number	BOM ID	Qty	Description
D-10906	7	1	3000mAh LIPO BATTERY
	8	1	CHARGING PORT 2
	9	1	CHARGING PORT 2 NUT
D-12344	10	1	QA MACHINED CASTING
	11	1	socket head cap screw_am

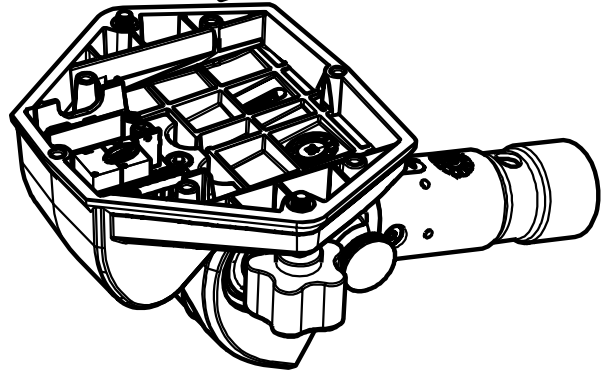

Part Number	BOM ID	Qty	Description
	7	1	91290A106 M2.5 SHCS
D-12614	8	1	JJ-JS-063 WIRELESS RECEIVER

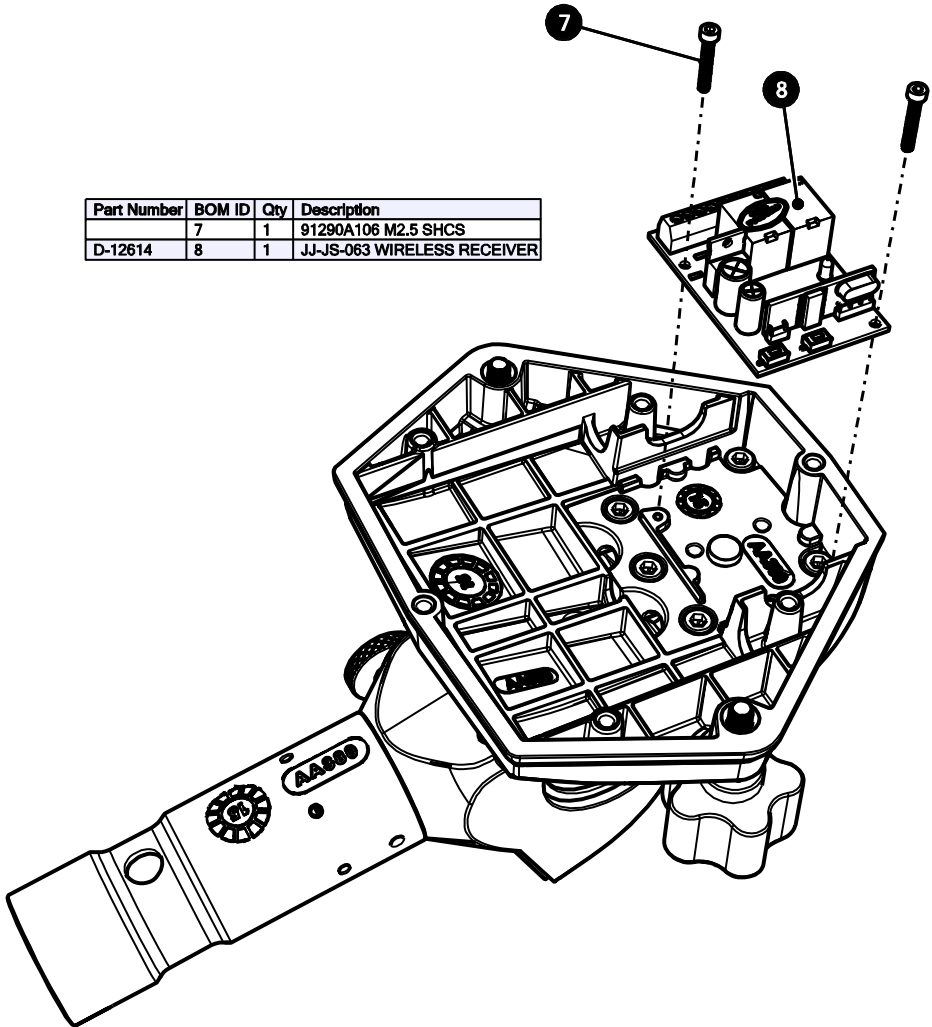

Part Number	Description	BOM ID	Qty
D-12759	334-800 MOTOR ASSEMBLY	1	1
D-12726	MAGVIBE PRO MOTOR MOUNT CASTING	2	1
	socket head cap screw_am	3	1

